

DATASHEET

HALFCOUPLER 300KG/50MM

■ Art.Nr. 151 50 300 12 T
 ■ Art.Nr. 151 50 300 12 TBK

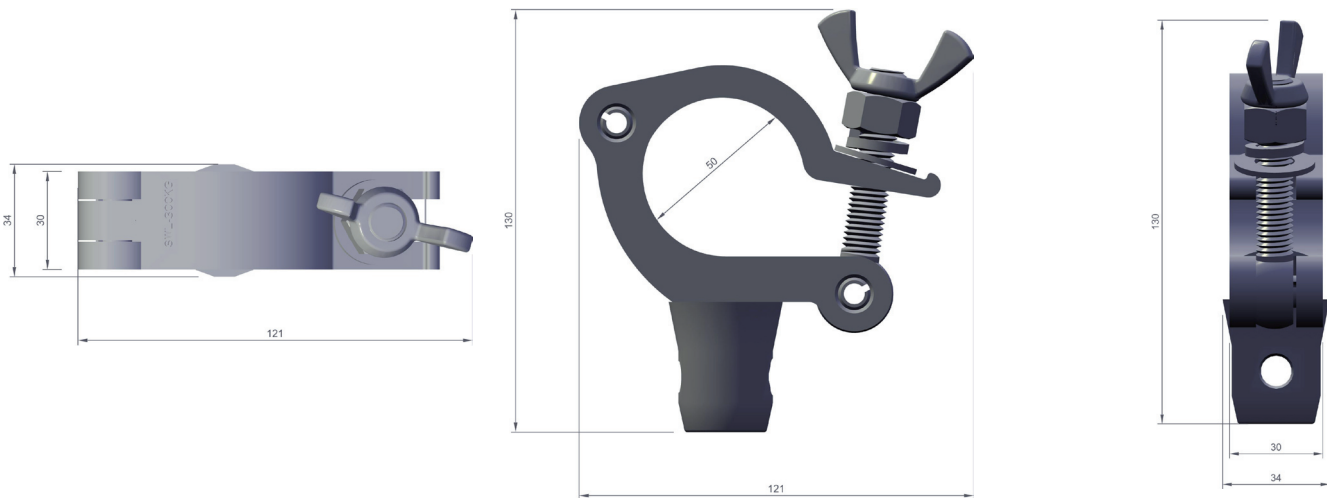

Rohrdurchmesser <i>Tube</i>	48-51 mm
Belastbarkeit (WLL) <i>Tensile load</i>	300 kg
Farbe <i>Colour</i>	silber / schwarz <i>silver / black</i>
Bauform <i>Variety</i>	Halbschelle mit Halbkonusverbinder HOFKON 290 <i>Halfcoupler with half conical connector HOFKON 290</i>
Verschluss <i>Screw plug</i>	M12 Flügelmutter, Unterlegscheibe <i>M12 wing nut, washer</i>
Abgang <i>Retaining screw</i>	M10 Senkkopfschraube, angeschraubter Halbkonus HOFKON 290 <i>M10 bolt, screwed half conical connector HOFKON 290</i>
Breite <i>Width</i>	30 mm
Zugbelastung <i>Tensile load</i>	300 kg
Material <i>Material</i>	Aluminium 6061 T6
Gewicht <i>Weight</i>	0,41 kg
Verpackungseinheit <i>Unit</i>	35 Stück <i>35 pieces</i>